



*Overview of Environmental
Studies at the Saline Water
Conversion Corporation, Saudi
Arabia*

by

Dr. Ibrahim A.R. Al-Tisan

Dr. Mohamed O. Saeed



Outline

- *Saline Water Conversion Corporation (SWCC)*
- *The impact of environment and impact of plant on coastal marine environment*
 - *Air Environment*
 - **Flue gases and control methods**
 - **Air-born contamination in desalination equipment**
 - *WATER ENVIRONMENT*
 - *Effect of Source Water on Desalination Plants*
 - *Effect of discharges on coastal environment*
- *Conclusions*



The Saline Water Conversion Corporation (SWCC)

- SWCC is a Government agency of the Kingdom of Saudi Arabia, responsible for the production of desalinated water.
- 70% of freshwater requirement of the Kingdom is met from seawater desalination plants on the shores of the Red Sea and Arabian Gulf.



Location and Production Capacity

- Present capacity of SWCC is 3 millions M³ per day of desalinated water produced at 15 sites: 12 sites on the Red Sea and 3 sites on the Gulf.
- Additionally, 74000 MWH of power are also generated by the SWCC plants.



Saline Water Conversion Corporation



Represents relative water production

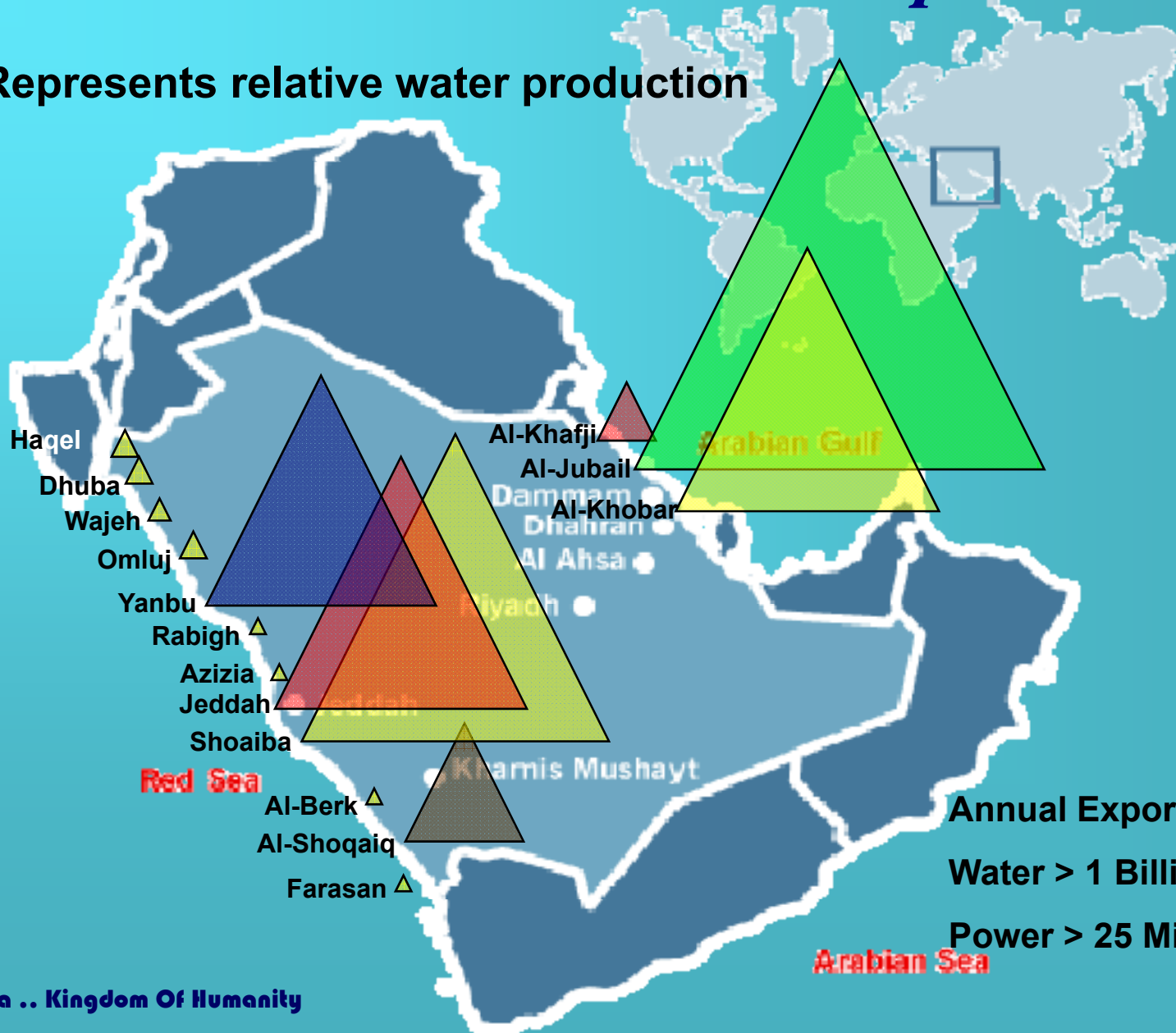



Size of Feed and Discharged Water

The product water constitutes only a small fraction from the feed water extracted for desalination.

The larger fraction, a huge quantity of water, is returned to sea in the form of brine reject.

- For example: the Jubail plants withdraw 400,000 m³ of seawater/hour.**
- Of this quantity, 340,000 m³/hour is discharged back into the sea.**



***THE IMPACT OF SEA ON DESALINATION
PLANTS AND THE IMPACT OF PLANTS ON
COASTAL MARINE ENVIRONMENT COULD
THEREFORE BE OF THE GREATEST
DIMENSION.***



SWCC needs a clean source water to feed its plants. Therefore, SWCC has great stakes in keeping clean environment and has dealt with this issue seriously. As a consequence:

- **The Research Institute is tasked with the responsibility of environmental assessment and corrective remedies.**
- **The Department of Research and Desalination Technologies, located in the SWCC Headquarters in Riyadh, established an environmental division to further coordinate with national, regional and international authorities on environmental issues.**
- **SWCC also formed an environment committee in the East and West coasts with environmental officers in each plant for on-site monitoring.**



IMPACT

- **SWCC plants could affect and in turn be affected by the environment.**
- **The impact involves air and coastal water environments.**



Air Environment

The Saline Water Desalination Research Institute (SWDRI) has consistently been engaged in carrying out research on reducing harmful emission gases from thermal power plants.

- Fuel oil used in boilers contains 3-4% sulfur and 40 mg/l vanadium**
- 95% of sulfur is oxidized to sulfur oxides resulting in emissions of hazardous gases, particulates and acid smut to the atmosphere**
- Corrosion also occurs in plants and outside materials.**



Emission Control

Two means were investigated for control of flue gas emission:

A) Desulfurization

Emitted gas is removed by absorption and adsorption.

Most commonly used process is absorption and involves transferring the gas into an absorbent which is normally liquid. The gas-absorbent mixture is then collected and disposed.

The gas from boiler is transferred first to electrostatic precipitator to remove ash and then into an absorbing chamber before exit to chimney.

- In SWCC Jeddah plants, lime and seawater are successfully used with a SO_2 removal of $> 90\%$.



Absorption treatment

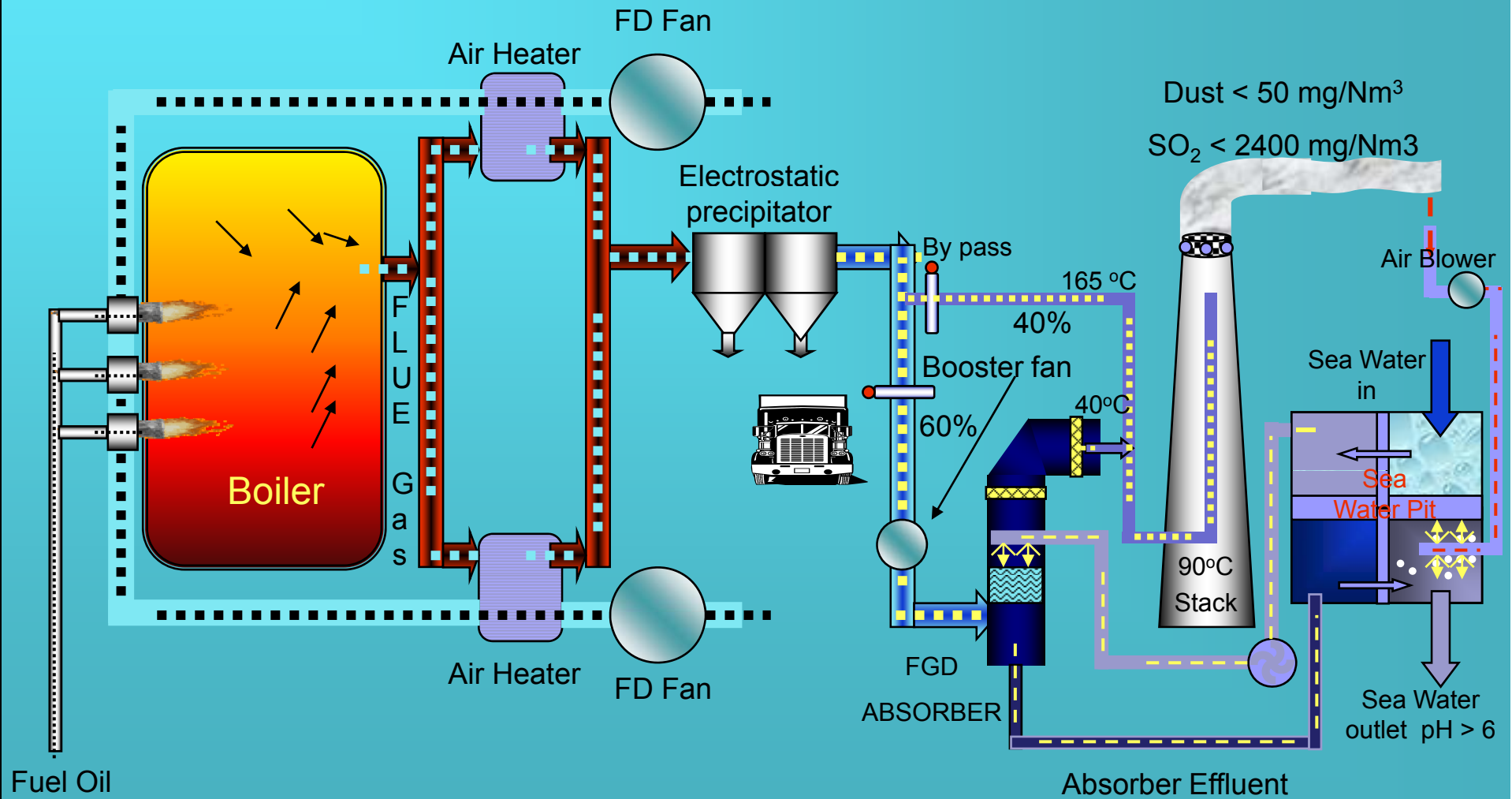

Fuel Oil Supply



B) Chemical Additives

- Addition of chemicals to fuel oil enhances boiler combustion and decreases harmful gas emission.

Effect of additives dosing on SO_3

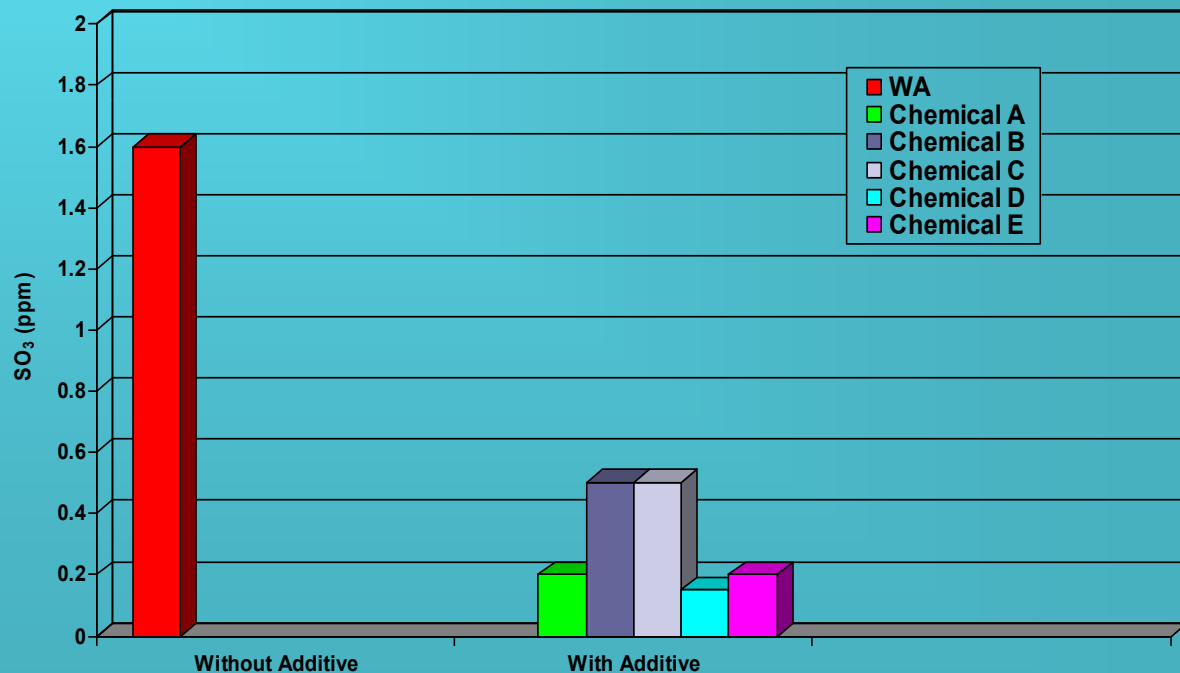



Air-born Contamination

Vice versa, air environment could also exert a negative impact on desalination plants e.g.

For example:

- Fungal infection of product hoses in a SWCC SWRO plant was found to originate from a stock of new hoses.
- New hoses infected with fungal spores which are invisible to the naked eye.
- When hose installed on membrane, spores grew into black fungal mass.



Photograph of a used product hose showing black slimy deposits which were identified as fungal growth mass



A photograph of a new product hose showing lack of fungus growth by the naked eye



WATER ENVIRONMENT

- 1) **Effect of Source** Water on Desalination Plants
- 2) **Effect of discharges** on coastal environment



1) Effect of Source Water on Desalination Plants

MARINE FOULING

- Fouling organisms pass fine mesh screens early in their life cycle as larvae
- Larvae mature inside the plants under conditions of insufficient residual chlorine
- An experiment investigated marine shell fouling in a condenser water box in Jubail MSF plants

Biofouling coupon study

- Fouling occurred with residual chlorine of 0.05-0.18mg/l.
- Problem alleviated by increasing and maintaining residual chlorine of 0.2-0.5 mg/l, as indicated by biofouling coupons fixed inside the water box.
- The photograph shows coupon after 9-month exposure. The coupon was devoid of any macrofouling settlement but with small polyethylene pieces.





Combating marine shell fouling

- ▶ **A new study is designed to study the life cycle of macrofouling organisms and environmentally friendly control methods:**
 - ❖ **At what stage of life cycle they enter plants?**
 - ❖ **Why not killed by chlorine?**
 - ❖ **Could antifouling paints which are devoid of toxic substances prohibit their attachment?**



Discharge channel of Jubail plants





Inherited anti-pollution design

- The discharge channel of Jubail plants is designed as such that it dissipates temperature.
- The channel is ~1.5 Km long and is cascading to the discharge point and there is sufficient mixing and air contact to reduce temperature.
- The added volume of cooling water in the discharge also helps to dilute chemical additives and salinity.



High SDI problem in Jeddah SWRO plants

- Drop in permeate quality attributed to interaction of chlorine and heavy metals in source water with consequent membrane oxidation.
- Problem alleviated by abandoning continuous chlorination in favor of intermittent chlorine injection.
- A rise in silt density index (SDI) posed yet another problem.
- Between 1997 and 2003, there were 16 instances of elevated SDI in the DMF filtrate.



- Problem investigated thoroughly between 2002-2004.**
- Main cause of problem is seasonal local currents bringing fine suspended silt to the plants' intake.**
- Fine silt escapes filtration.**
- At times, elevated biological growth (plankton) contributes to the problem.**



Variation of TSS, SDI, and TOC with pretreatment during normal and high SDI periods, SWCC Jeddah Desalination and Power Plants

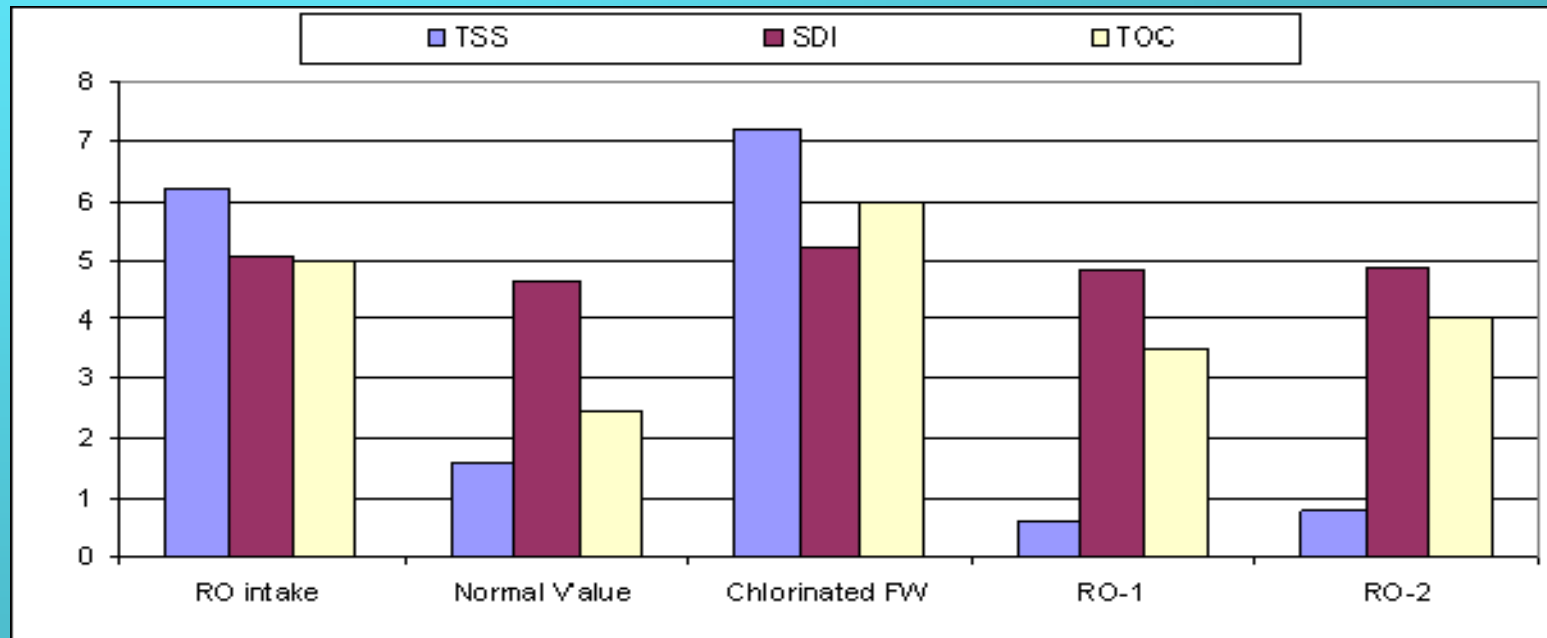

1. RO-1 and RO-2 are pretreated and filtered RO feed water
2. Percent TSS removal is 91.7% for RO-1 and 88.9% for RO-2
3. All bar profiles indicate a period of high SDI except that designated as normal



Biofouling Potential of Source Water

- **Studies were carried out to determine why some SWRO plants experience fouling and others not.**
- **The difference is traced to source water quality.**



SEM of a biofilms slide from the intake lagoon of Jubail plant

Note the lack of a filamentous network and entrapped material noticed in the bottom slide. A SWRO plant sourced from this location without chlorination has no history of operational problems

Note the formation of a net work of algal filaments with entrapped debris and bacterial cells. A SWRO plant sourced from this location with chlorination experiences filtration and membrane fouling problems.





OTHER EFFECTS

- Desalination plants are also subject to sudden effects of natural phenomena:
 - Swarms of Jellyfish
 - Ingress of Jellyfish could lead to total shutdowns.
 - Mass mortality of fish and red tide
 - Could physically interfere with water intake structures and negatively affect aesthetic value of air and water.



2) Effect of discharges on coastal environment

- ❑ Extensive studies show the discharge from desalination and power plants to exert very benign effect on coastal environment**

For example:



Effect of Discharges on Primary Productivity in Terms of Chlorophyll

Location	Chlorophyll Concentration (mg/m ³)			
	Discharge site	500m from discharge	1000m from discharge	Open sea
Jubail (depth ~4m)	0.50	2.50	2.60	2.60
Jeddah (depth >30m)	*0.51	0.32	0.22	0.22

Note: At Jubail normal primary production regained at 500m from discharge.

At Jeddah discharge site is more productive than open sea.



Heavy metals

➤ Seasonal distribution of trace metals ($\mu\text{g/l}$) at different sites in the near shore waters of Jubail desalination and power plants

➤ Metal concentration in discharge zone similar to open sea

Trace Metals ($\mu\text{g/L}$)	Sampling sites/Seasons			
	Intake Bay	Open Sea	Outfall Bay	Recovery Zone (1 km)
<i>Iron</i>				
Winter	7.4	8.2	8.5	7.1
Spring	3.0	3.5	3.3	2.9
Fall	2.6	2.5	1.0	5.6
<i>Arsenic</i>				
Winter	4.4	4.6	4.9	5.0
Spring	2.6	2.3	3.4	3.2
Fall	2.5	3.6	3.2	3.1
<i>Copper</i>				
Winter	4.7	5.2	6.2	5.0
Spring	0.85	2.3	1.6	2.1
Fall	3.9	3.5	2.3	5.0
<i>Nickel</i>				
Winter	1.3	1.3	1.3	1.0
Spring	0.31	0.38	0.33	0.34
Fall	0.27	0.36	0.21	0.4
<i>Cobalt</i>				
Winter	0.0	0.0	0.0	0.09
Spring	0.63	0.41	0.44	0.37
Fall	0.18	0.12	0.18	0.14
<i>Lead</i>				
Winter	0.27	0.32	0.49	0.24
Spring	0.43	0.45	0.52	0.69
Fall	1.7	0.9	0.65	1.1
<i>Chromium</i>				
Winter	0.0	0.13	0.0	0.11
Spring	0.0	0.0	0.0	0.00
Fall	0.18	0.09	0.04	0.15



Physico-chemical parameters

Distribution of major seawater quality parameters during different seasons in the near-shore waters of Jubail Desalination and Power Plants during 1995.

Parameters/Seasons	Sampling sites			
	Intake Bay	Open Sea	Outfall Mixing Bay	Recovery Zone (1 Km)
<i>Sea surface temperature (°C)</i>				
Winter	17.90 ± 0.85	17.80 ± 1.06	27.30 ± 2.47	20.50 ± 4.95
Spring	24.42 ± 5.10	24.00 ± 4.09	33.08 ± 4.06	25.91 ± 5.59
Summer	30.25 ± 0.35	30.75 ± 1.06	37.25 ± 0.35	34.38 ± 3.71
Fall	27.00 ± 1.41	27.00 ± 1.41	34.50 ± 0.71	30.00 ± 2.82
<i>Conductivity (Milli seimens/cm)</i>				
Winter	57.28 ± 4.70	57.58 ± 5.90	67.33 ± 1.23	60.15 ± 6.15
Spring	58.83 ± 1.33	59.56 ± 3.11	65.55 ± 2.65	61.21 ± 1.62
Summer	63.85 ± 1.77	63.73 ± 1.66	69.53 ± 2.65	68.58 ± 3.57
Fall	61.15 ± 1.49	61.60 ± 0.00	67.40 ± 4.53	64.43 ± 1.66
<i>pH</i>				
Winter	8.36 ± 0.00	8.38 ± 0.02	8.39 ± 0.02	8.39 ± 0.00
Spring	8.29 ± 0.06	8.31 ± 0.06	8.32 ± 0.05	8.31 ± 0.05
Summer	8.34 ± 0.06	8.35 ± 0.06	8.34 ± 0.04	8.34 ± 0.06
Fall	8.60 ± 0.22	8.61 ± 0.21	8.63 ± 0.24	8.67 ± 0.17
<i>Dissolved Oxygen (mg/L)</i>				
Winter	6.88 ± 0.56	6.98 ± 0.41	6.36 ± 0.61	6.65 ± 0.00
Spring	6.66 ± 0.52	6.85 ± 0.79	6.18 ± 0.49	6.27 ± 0.54
Summer	5.24 ± 0.68	5.46 ± 0.27	5.34 ± 0.44	5.17 ± 0.29
Fall	5.22 ± 1.09	4.89 ± 0.69	4.86 ± 0.45	5.17 ± 0.00
<i>TSS (mg/L)</i>				
Winter	30.70 ± 11.88	28.56 ± 9.62	29.57 ± 6.11	24.56 ± 0.45
Spring	40.03 ± 39.43	16.66 ± 4.45	19.28 ± 1.89	16.16 ± 4.79
Summer	14.18 ± 3.94	19.45 ± 0.71	18.52 ± 1.87	14.89 ± 11.58
Fall	10.49 ± 1.99	13.89 ± 1.39	13.85 ± 1.59	13.55 ± 0.55



Temperature profile



Temperature profile at Jubail plants in 2002 at 500, 1000 and 300m from intake and discharge sites.

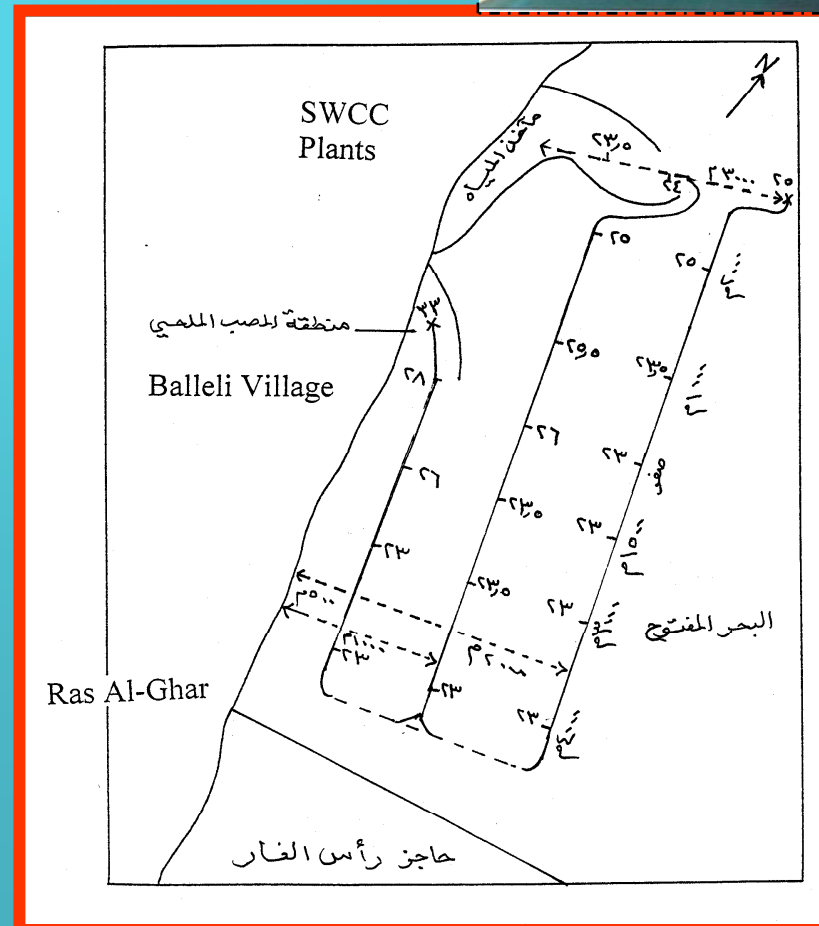



CONCLUSIONS

- The Kingdom of Saudi Arabia is a signatory of all international and regional environmental agreements.
- The kingdom has established environmental agencies which deal with a multitude of environmental issues.
- The Kingdom's growing concern about the environment is reflected in the SWCC's establishment of a desalination research institute, an environmental department and environmental committees.
- The success of desalination depends on the proper management of the pristine environment.



- Intensive environmental measurements are being carried out in conjunction with various research projects. Results obtained to date indicate that desalination discharges to coastal water did not hinder biological productivity or deteriorate water quality.
- Also, the diversity of various groups of organisms in the discharge sites remains similar to that in the open sea. Mortality of any group of animals has not been noticed in any of the desalination sites. No heavy metal or organic pollution is recorded. Reports of coastal water pollution resulting from SWCC desalination should be interpreted with due caution.



- **Source water and air in the vicinity of desalination plants could cause serious operational problems such as membrane biofouling.**
- **As a service to the public, the SWCC Desalination Research Institute will consider outside requests to investigate environmental issues and, where necessary, carry out relevant analyses.**

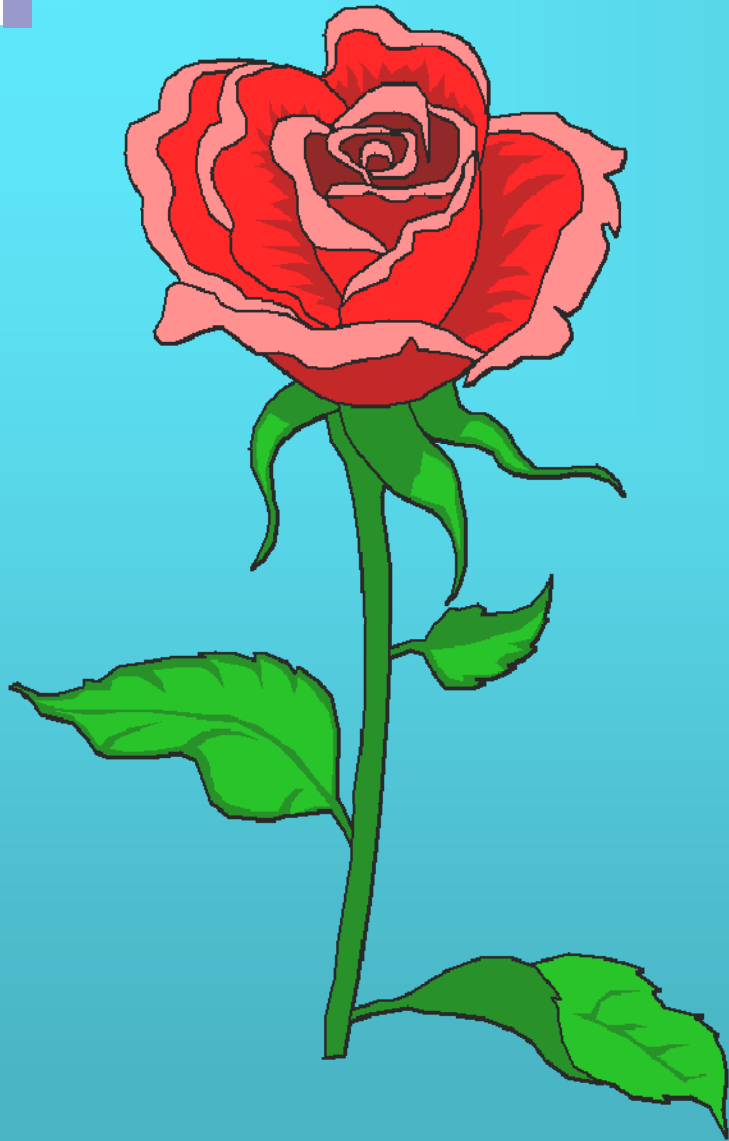

THANK

YOU